

Outdoor single-pole disconnectors DRIBO Firm

rated voltage 25 and 38.5 kV
rated current 400 and 1200 A



DRIBO, spol. s r.o.

Pražákova 36
619 00 Brno
Czech Republic

Tel.: +420 533 101 111, Fax: +420 543 216 619, E-mail: dribo@dribo.cz, Internet: <http://www.dribo.eu>

ISO 9001
ISO 14001
BUREAU VERITAS
Certification



Outdoor single-pole disconnectors DRIBO Flrm

These switching devices are used for the disconnection of end-position substations and parts of the no-load power lines. The DRIBO Flrm disconnectors are equipped with a simple arc quenching equipment, which provides for breaking of the circuit irrespective of the speed of manipulation. Disconnectors for rated voltage of 25 kV were tested with satisfactory results for the no-load opening of distribution transformer circuits with rated power of 630 kVA. When transformer circuits are opened under no-load conditions, no significant overvoltage effects are taking place.

The Flrm-k type disconnectors are designed for mounting on a console; those of Flrm-v type are designed for mounting within the range of the line span.

The disconnectors comply with the requirements of the EN 62271-1 and EN 62271-102 standards. The insulators used at the disconnectors meet the requirements on pollution class IV to ČSN 33 0405.

The easy and rugged design of the disconnectors provides for the reliability of their operation in the most different climatic environments.

Parts of the supporting structure are made of hot-galvanized steel; the contact springs, small parts of the locking mechanism and arc-quenching contacts are made of stainless steel.

Under normal operating conditions the disconnectors do not necessitate any maintenance and, therefore, are maintenance free over a period of twenty years.

All current-carrying parts are manufactured of galvanically silvered electrolytical copper.

The dimensioning of the conductors of which the current-carrying path consists, as well as the contact pressure of stainless steel springs are one of the prerequisites for a defect-free switching, even after many years of operation of the disconnector in the most severe operating conditions and also in ice-accretion conditions.

The self cleaning surface of the Fiberlink brand suspension insulators used, with silicon insulation, guarantees, with a high margin, the long-time insulation properties of the disconnector over the isolating distance, at areas with a high level of air pollution and under rain conditions. The short-circuit withstand capabilities are met with a big margin.

The well-proven structural elements are the result of long-term experience, which, along with the quality of material used and the accuracy of production, guarantee low operation and maintenance costs of the switching device.

The control of the disconnectors is done using 5 to 6 m long switching rods, or using rods being the part of the „Powerman Hot“ handling set with a special attachment that have been tested also for operation in rainy conditions.

Technical data

Rated voltage	U	kV	25	38,5	38,5
rated current	I_r	A	400	400	1200
rated short-time current	I_k	kA	16	16	20
rated dynamic current	I_p	kA	40	40	50
permitted tension during the operation		kN	30	30	30
smallest phase pitch when placing the disconnectors side by side		mm	800	1200	1200
smallest phase pitch in off-tracking position of the middle phase		mm	500	700	700
rated short-time withstand power frequency voltage / 1min. to be applied in both dry and wet conditions across the isolating distance		kV	60	90	90
rated lightning pulse withstand voltage across the isolating distance		kV	145	210	210

Function description

Opening:

By pulling the on the control rod suspended over the upper edge of the control lever **6** the locking mechanism **5** opens, which releases the switching knife contact **1**. After loosening the switching knife contact, the current flows through by the arc quenching circuit **15**, connected in parallel. After having reached a distance, which is adequate for safe opening the disconnector opens in a quick-acting way, independent of the operation speed of the disconnector. By further application of pulling forces this contact achieves its opened switching position (vertical position).

Closing:

Applying pressure of the operation rod on the bottom edge of the control lever **6** introduces the switching knife contact **1** into the guiding fork **4** and farther to the slide contact **3**. When reaching the end position the locking mechanism **5** locks the switching knife contact **1** in ON position. The quick-opening mechanism is activated during the closing operation.

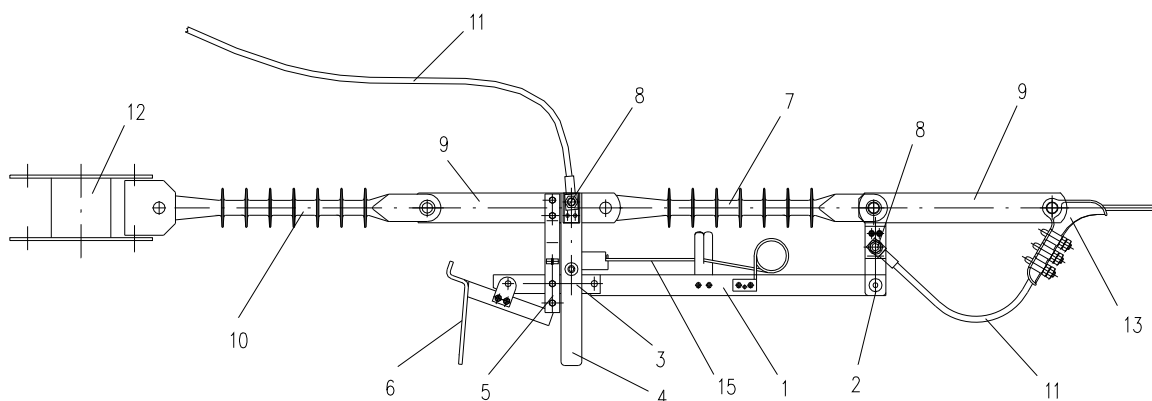

The **Firm-k** disconnector mounted on the anchoring insulator

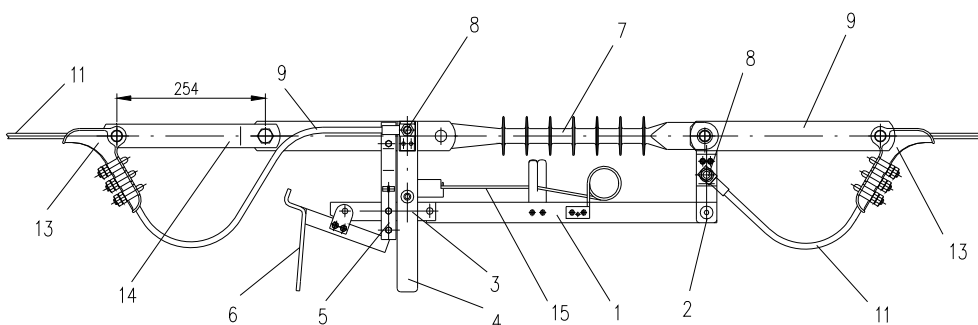

The **Firm-v** disconnector suspended on conductors

- | | | |
|---------------------------|--------------------------|------------------------------------|
| 1 switching knife contact | 6 control lever | 11 incoming conductor * |
| 2 rotating contact | 7 insulator | 12 anchoring fixture * |
| 3 sliding contact | 8 incoming terminal M12 | 13 anchoring clamp terminal * |
| 4 guiding fork | 9 fixture | 14 extension piece – fork with lug |
| 5 locking mechanism | 10 anchoring insulator * | 15 quick-opening mechanism |

* does not constitute a part of the delivery

Single-pole disconnectors DRIBO Flrm

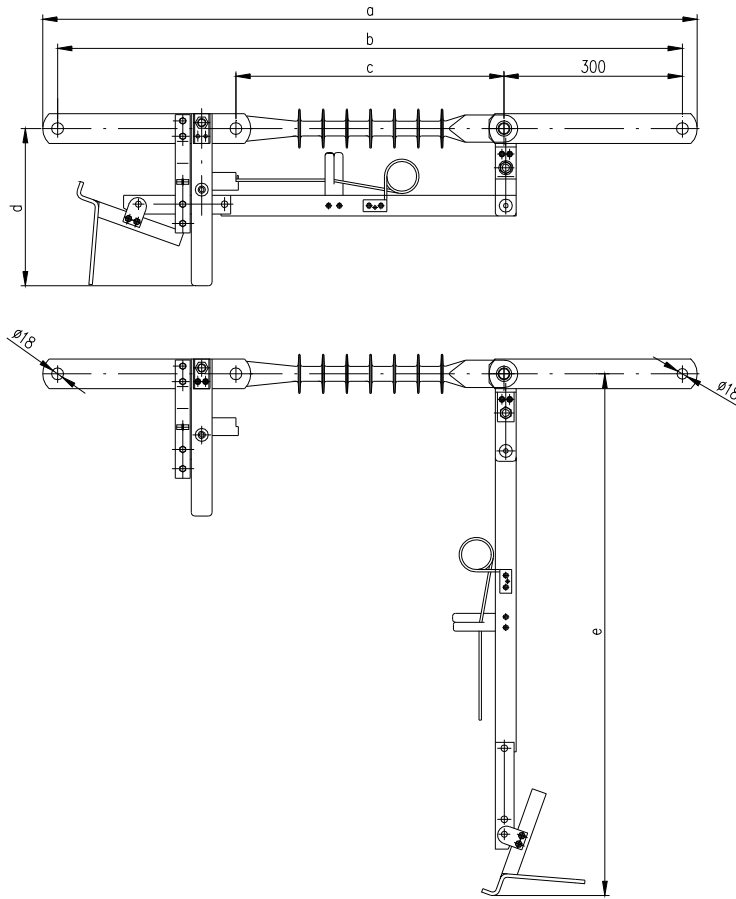

rated voltage kV	type	part nr.	rated current A	a mm	b mm	c mm	d mm	e mm	weight kg
25	Flrm-k	095 0541M	400	1101	1051	451	265	880	6,0
25	Flrm-v	095 0541MV	400	1101	1051	451	265	880	7,1
38,5	Flrm-k	095 0542M	400	1222	1172	572	265	1000	6,4
38,5	Flrm-v	095 0542MV	400	1222	1172	572	265	1000	7,5
38,5	Flrm-k	095 0543M	1200	1222	1172	572	237	1000	7,1
38,5	Flrm-v	095 0543MV	1200	1222	1172	572	237	1000	8,2

The Flrm-v disconnectors are delivered inclusive of the fork with lug – manufactured by the company ELBA, part No. 211 531.